



Features

- Single Power Supply 3.0V to 3.6V
- 24dB Minimum Gain
- Input Matched to 50Ω
- 2400MHz to 2500MHz Frequency Range
- +18dBm at <2.5% typ EVM, 120mA at 3.3V_{CC}

Applications

- IEEE802.11b/g/n WLAN Applications
- 2.5GHz ISM Band Applications
- Commercial and Consumer Systems
- Portable Battery-Powered Equipment
- Spread-Spectrum and MMDS Systems

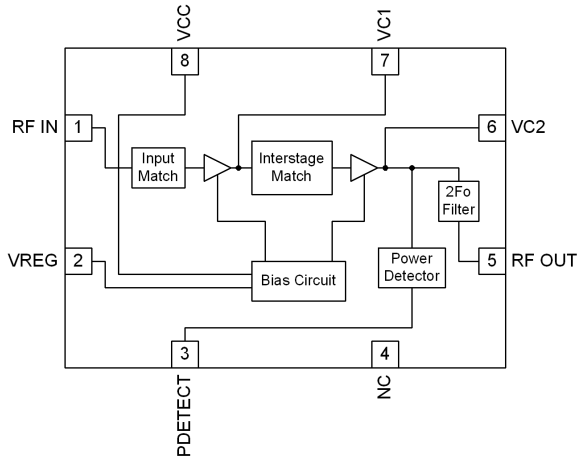

Functional Block Diagram

Product Description

The RF5722 is a linear, medium-power, high-efficiency, two-stage amplifier IC designed specifically for battery-powered WLAN applications such as PC cards, mini PCI, and compact flash applications. The device is manufactured on an advanced InGaP Gallium Arsenide Heterojunction Bipolar Transistor (HBT) process, and has been designed for use as the final RF amplifier in 2.5GHz OFDM and other spread-spectrum transmitters. The device is provided in a 2.2mmx2.2mm, 8-pin, QFN with a backside ground. The RF5722 is designed to maintain linearity over a wide range of supply voltages and power outputs. The RF5722 also has built-in power detector and incorporates the input, and interstage components internally which reduces the component count used externally and makes it easier to incorporate on any design.

Ordering Information

RF5722	3.0V to 3.6V, 2.4GHz to 2.5GHz Linear Power Amplifier
RF5722PCK-410	Fully assembled evaluation board tuned for 2.4 to 2.5 GHz and 5 piece loose samples

Optimum Technology Matching® Applied

- | | | | |
|---|--------------------------------------|-------------------------------------|-----------------------------------|
| <input type="checkbox"/> GaAs HBT | <input type="checkbox"/> SiGe BiCMOS | <input type="checkbox"/> GaAs pHEMT | <input type="checkbox"/> GaN HEMT |
| <input type="checkbox"/> GaAs MESFET | <input type="checkbox"/> Si BiCMOS | <input type="checkbox"/> Si CMOS | <input type="checkbox"/> RF MEMS |
| <input checked="" type="checkbox"/> InGaP HBT | <input type="checkbox"/> SiGe HBT | <input type="checkbox"/> Si BJT | <input type="checkbox"/> LDMOS |

RF MICRO DEVICES®, RFMD®, Optimum Technology Matching®, Enabling Wireless Connectivity™, PowerStar®, POLARIS™ TOTAL RADIO™ and UltimateBlue™ are trademarks of RFMD, LLC. BLUETOOTH is a trademark owned by Bluetooth SIG, Inc., U.S.A. and licensed for use by RFMD. All other trade names, trademarks and registered trademarks are the property of their respective owners. ©2006, RF Micro Devices, Inc.

Absolute Maximum Ratings

Parameter	Rating	Unit
Supply Voltage	-0.5 to +5.0	V _{DC}
Power Control Voltage (V _{REG})	-0.5 to 3.5	V
DC Supply Current	400	mA
Input RF Power	+5	dBm
Operating Ambient Temperature	-30 to +85	°C
Degraded Performance	-30 to -10	°C
Storage Temperature	-40 to +150	°C
Moisture Sensitivity	TBD	
ESD HBM	TBD	V
MM	TBD	V



Caution! ESD sensitive device.

Exceeding any one or a combination of the Absolute Maximum Rating conditions may cause permanent damage to the device. Extended application of Absolute Maximum Rating conditions to the device may reduce device reliability. Specified typical performance or functional operation of the device under Absolute Maximum Rating conditions is not implied.

RoHS status based on EU Directive 2002/95/EC (at time of this document revision).

The information in this publication is believed to be accurate and reliable. However, no responsibility is assumed by RF Micro Devices, Inc. ("RFMD") for its use, nor for any infringement of patents, or other rights of third parties, resulting from its use. No license is granted by implication or otherwise under any patent or patent rights of RFMD. RFMD reserves the right to change component circuitry, recommended application circuitry and specifications at any time without prior notice.

Parameter	Specification			Unit	Condition
	Min.	Typ.	Max.		
Overall					Temperature = +25 °C, V _{CC} = 3.3V, V _{REG} = 2.85V pulsed at 1% to 100% duty cycle, Frequency = 2450MHz, circuit per evaluation board schematic, unless otherwise specified
Frequency	2.40		2.50	GHz	IEEE802.11g IEEE802.11n
Output Power	17	18		dBm	At max data rate, OFDM modulation
EVM*		2.5	4	%	RMS, mean
Gain	24	25.5		dB	At +18dBm RF P _{OUT} and 54Mbps
Gain Variance			1.25	±dB	-30 °C to +85 °C
Power Detector					
	P _{OUT} = 18dBm	0.85	1.25	V	
Current					
	Operating	120	160	mA	At +18dBm RF P _{OUT} and 54Mbps
	11b Operating		175	mA	At +20dBm and 1Mbps
	Quiescent	85		mA	Data rate at ≤3.5% EVM RMS, mean, T = -30 °C to +50 °C
I _{REG} Current		2		mA	V _{CC} = +3.3V _{DC}
Shutdown			10	μA	
Power Supply	3.0	3.3	3.6	V _{DC}	Operating Range
V _{REG1} , V _{REG2} Input Voltage	2.75	2.85	2.9	V _{DC}	Operating Range
Output VSWR			10:1		
Input Return Loss		-15	-10	dB	
Turn-on Time**		0.5	1.0	μS	Output stable to within 90% of final gain
Second Harmonic			-43	dBm	Fundamental frequency is between 2400MHz and 2500MHz; RF P _{OUT} = +18dBm. See note 2.
ACP Lower		-53	-50		18.5dBm (min), -20dBm (typ.)
ACP Upper		-33	-30		18.5dBm (min), -20dBm (typ.)

Notes: *The EVM specification is obtained with a signal generator that has an EVM floor of less than 0.7%.

**The PA must operate with gated bias voltage input at 1% to 99% duty cycles without any EVM or other parameter degradation.

Note 2: For best harmonic rejection please refer to the harmonic rejection application schematic.

Pin	Function	Description
1	RF IN	RF input. Input is matched to 50Ω and DC block is provided internally.
2	VREG	Bias current control voltage for the first and second amplifier stage.
3	PDETECT	Power detector which provides an output voltage proportional to the RF output power level. May need external decoupling capacitor for stability. May need external circuitry to bring output voltage to desired level.
4	GND	Ground.
5	RF OUT	RF Output.
6	VC2	Voltage supply for the second amplifier stage.
7	VC1	Voltage supply for the first amplifier stage.
8	VCC	Supply voltage for the bias reference and control circuit. May be connected with V _{C1} and V _{C2} (with a single supply voltage) as long as V _{CC} does not exceed +4.5V _{DC} in this configuration.
Pkg Base	GND	The center metal base of the QFN package provides DC and RF ground as well as heat sink for the amplifier.

Package Drawing

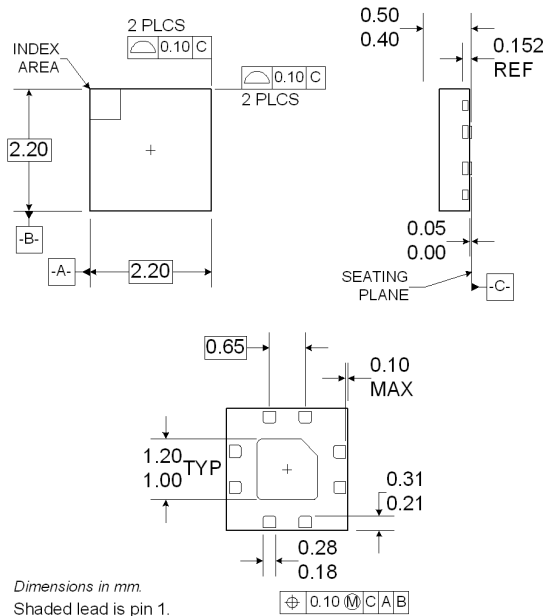

Pin Out

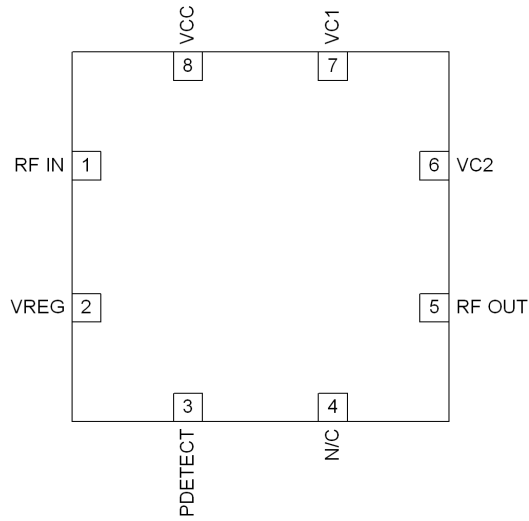

Application Schematic

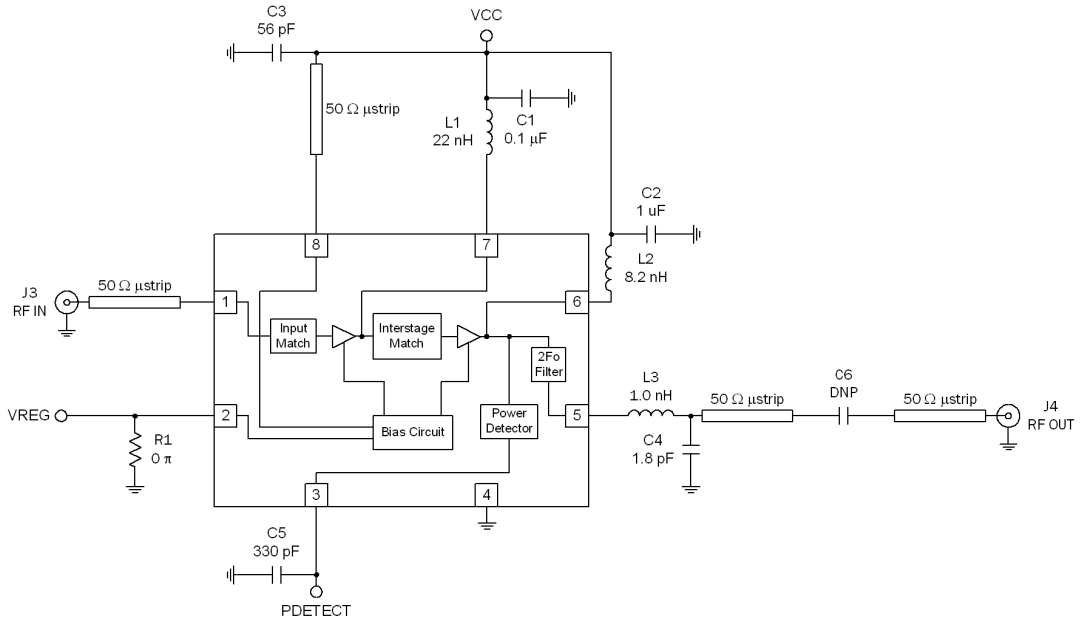

Theory of Operation and Application Information

The RF5722 is a two-stage power amplifier (PA) with a minimum gain of 24dB minimum gain in the 2.4GHz to 2.5GHz ISM band. The RF5722 has integrated input, interstage and output matching components thus allowing minimal bill of material (BOM) parts count in end applications. The RF5722 is designed primarily for IEEE802.11b/g/n WLAN applications where the available supply voltage and current are limited. This amplifier will operate to (and below) the lowest expected voltage made available by a typical PCMCIA slot in a laptop PC, and will maintain required linearity at decreased supply voltages.

The RF5722 requires only a single positive supply of 3.3V nominal (or greater) to operate to full specifications. Power control is provided through one bias control input pin (V_{REG}). DC blocking caps are provided internally and the evaluation board circuit (available from RF Micro Devices, Inc. (RFMD)) is optimized for 3.3V_{DC} applications.

For best results, the PA circuit layout from the evaluation board should be copied as closely as possible, particularly the ground layout and ground vias. Pin 4 *must* be left as a no-connect on the PCB in order for the PA to work properly. Other configurations may also work, but the design process is much easier and quicker if the layout is copied from the RF5722 evaluation board. Gerber files of RFMD PCBA designs can be provided on request. The RF5722 is a very easy part to implement, but care in circuit layout and component selection is always advisable when designing circuits to operate at 2.5GHz. The RF5722 evaluation board layout and schematic are available using 0201 (US) size components which will help shrink the overall size of the total area of the PA and components of the intended design. Please contact RFMD Sales or Application Engineering for additional data and guidance.

For best performance, it is important to duplicate (as closely as possible) the layout of the evaluation board. The RF5722 has primarily been characterized with a voltage on V_{REG} of 2.8V_{DC}. If you prefer to use a control voltage that is significantly different than 2.8V_{DC}, or a different frequency than the recommended frequency range, contact RFMD Sales or Applications Engineering for additional data and guidance.

QFN8 Package Area versus Other Small Form Factor Package Areas

Package Type	Length (mm)	Width (mm)	Area (mm ²)	Delta (Δ) (mm ²) to QFN8
SOT 23-6	3.1	3.0	9.30	4.46
QFN12	3.0	3.0	9.00	4.16
SOT 23-5	2.9	2.8	8.12	3.28
QFN8	2.2	2.2	4.84	0.00

An application schematic for 2.5GHz operation is included that has two additional components, one shunt inductor, and one shunt capacitor, on the output for improved second harmonic rejection. This layout provides ~20dB rejection at 5GHz with a minimal BOM count.

Evaluation Board Schematic

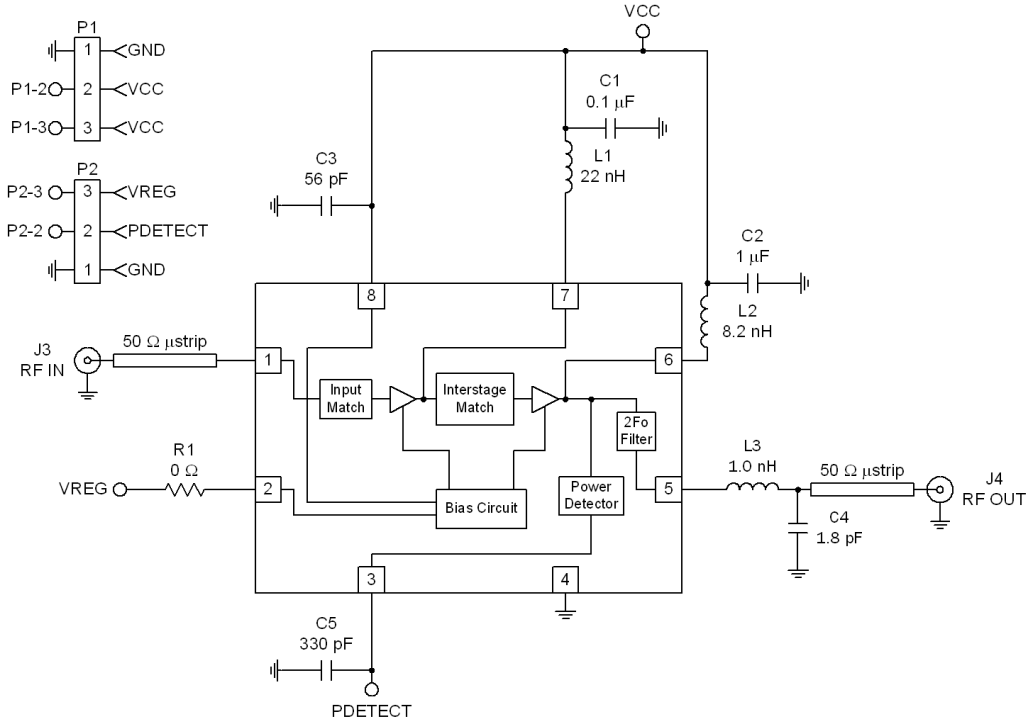

Evaluation Board Layout

Board Size 1.0" x 1.0"

Board Thickness 0.031"; Board Material FR-4; Multi-Layer

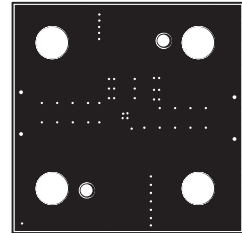
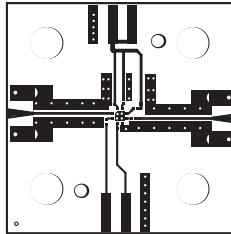
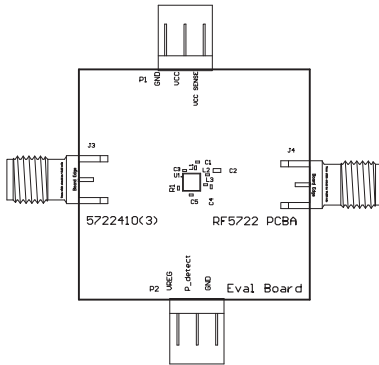

V_{CC}=3.3V: EVM versus P_{OUT}

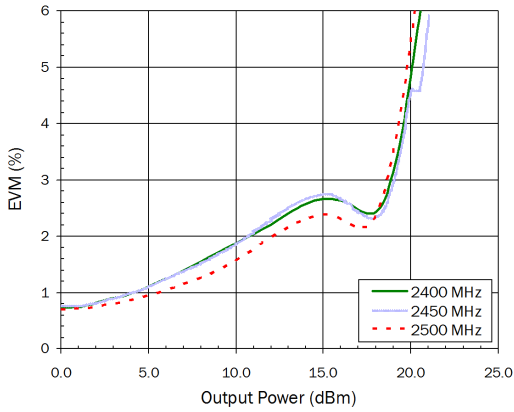

V_{CC}=3.3V: Gain versus P_{OUT}

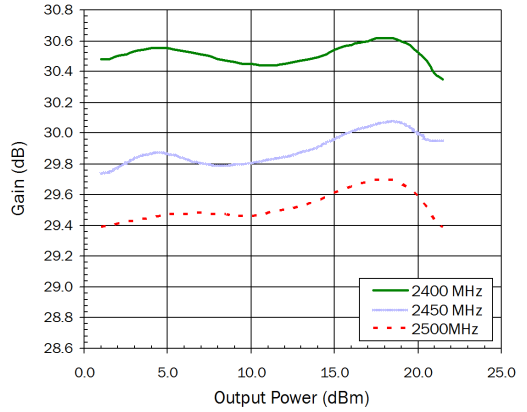

V_{CC}=3.3V: I_{CC} versus P_{OUT}

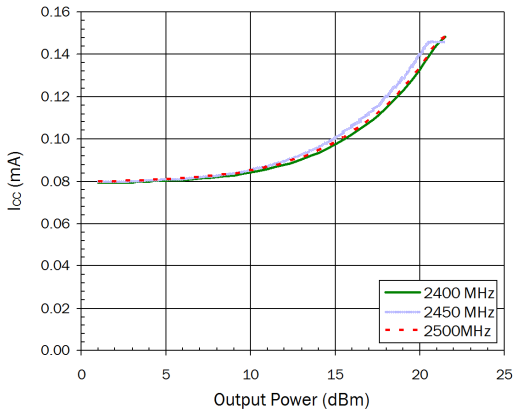

V_{CC}=3.3V: P_{DETECT} versus P_{OUT}

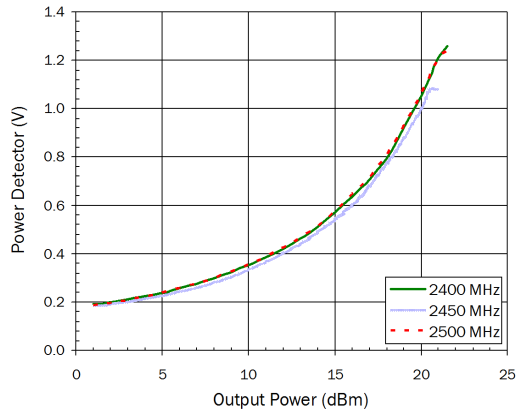

PCB Design Requirements

PCB Surface Finish

The PCB surface finish used for RFMD's qualification process is electroless nickel, immersion gold. Typical thickness is 3µinch to 8µinch gold over 180µinch nickel.

PCB Land Pattern Recommendation

PCB land patterns are based on IPC-SM-782 standards when possible. The pad pattern shown has been developed and tested for optimized assembly at RFMD; however, it may require some modifications to address company specific assembly processes. The PCB land pattern has been developed to accommodate lead and package tolerances.

PCB Metal Land Pattern

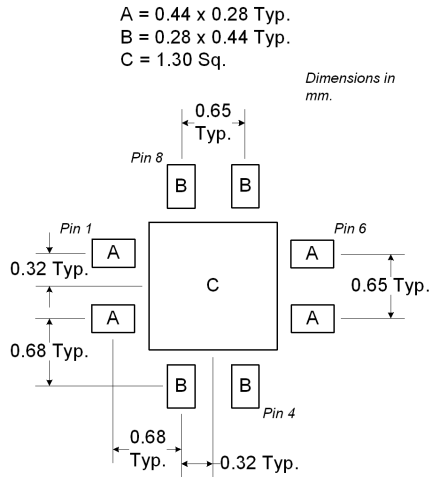

PCB Solder Mask Pattern

Liquid Photo-Imageable (LPI) solder mask is recommended. The solder mask footprint will match what is shown for the PCB metal land pattern with a 2mil to 3mil expansion to accommodate solder mask registration clearance around all pads. The center-grounding pad shall also have a solder mask clearance. Expansion of the pads to create solder mask clearance can be provided in the master data or requested from the PCB fabrication supplier.

A = 0.57 x 0.41 Typ.

B = 0.41 x 0.57 Typ.

C = 1.20 Sq.

Dimensions in mm.

