



Features

- Excellent Linearity
- Superior Return Loss Performance
- Extremely Low Distortion
- Optimal Reliability
- Low Noise
- Unconditionally Stable Under All Terminations
- 22.5 dB Min. Gain at 1200 MHz
- 240 mA Max. at 24V_{DC}

Applications

- 45 MHz to 1200 MHz CATV Amplifier Systems

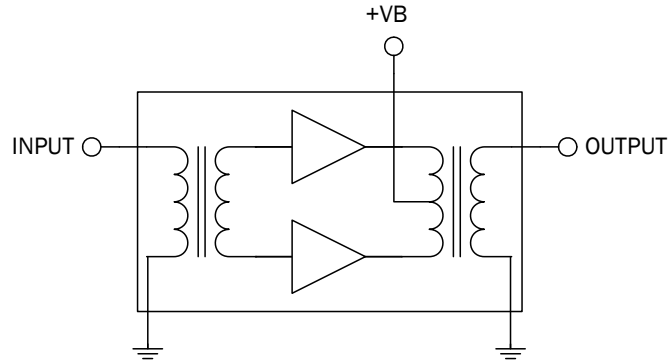

Functional Block Diagram

Product Description

The RFPP2590 is a Hybrid Push Pull amplifier module. The part employs GaAs die and operates from 45 MHz to 1200 MHz. It provides excellent linearity and superior return loss performance with low noise and optimal reliability.

Ordering Information

RFPP2590 45 MHz to 1200 MHz GaAs Push Pull Hybrid

Optimum Technology Matching® Applied

- | | | | |
|---|--------------------------------------|-------------------------------------|------------------------------------|
| <input type="checkbox"/> GaAs HBT | <input type="checkbox"/> SiGe BiCMOS | <input type="checkbox"/> GaAs pHEMT | <input type="checkbox"/> GaN HEMT |
| <input checked="" type="checkbox"/> GaAs MESFET | <input type="checkbox"/> Si BiCMOS | <input type="checkbox"/> Si CMOS | <input type="checkbox"/> BiFET HBT |
| <input type="checkbox"/> InGaP HBT | <input type="checkbox"/> SiGe HBT | <input type="checkbox"/> Si BJT | <input type="checkbox"/> LDMOS |

RF MICRO DEVICES®, RFMD®, Optimum Technology Matching®, Enabling Wireless Connectivity™, PowerStar®, POLARIS™ TOTAL RADIO™ and UltimateBlue™ are trademarks of RFMD, LLC. BLUETOOTH is a trademark owned by Bluetooth SIG, Inc., U.S.A. and licensed for use by RFMD. All other trade names, trademarks and registered trademarks are the property of their respective owners. ©2006, RF Micro Devices, Inc.

Absolute Maximum Ratings

Parameter	Rating	Unit
RF Input Voltage (single tone)	75	dBmV
DC Supply Over-Voltage (5 minutes)	30	V
Storage Temperature	-40 to +100	°C
Operating Mounting Base Temperature	-30 to +100	°C



Caution! ESD sensitive device.

Exceeding any one or a combination of the Absolute Maximum Rating conditions may cause permanent damage to the device. Extended application of Absolute Maximum Rating conditions to the device may reduce device reliability. Specified typical performance or functional operation of the device under Absolute Maximum Rating conditions is not implied.

RoHS status based on EU Directive 2002/95/EC (at time of this document revision).

The information in this publication is believed to be accurate and reliable. However, no responsibility is assumed by RF Micro Devices, Inc. ("RFMD") for its use, nor for any infringement of patents, or other rights of third parties, resulting from its use. No license is granted by implication or otherwise under any patent or patent rights of RFMD. RFMD reserves the right to change component circuitry, recommended application circuitry and specifications at any time without prior notice.

Parameter	Specification			Unit	Condition
	Min.	Typ.	Max.		
Overall					$V_B = 24V, T_{MB} = 30^\circ C, Z_S = Z_L = 75\Omega$
Power Gain	21.5	22	22.5	dB	f = 45MHz
	22.5	23.5	24.0	dB	f = 1200MHz
Slope [1]	1.0	1.5	2.0	dB	f = 45MHz to 1200MHz
Flatness of Frequency Response			0.8	dB	f = 45MHz to 1200MHz
Input Return Loss	-20			dB	f = 45MHz to 320MHz
	-19			dB	f = 320MHz to 640MHz
	-18			dB	f = 640MHz to 870MHz
	-18			dB	f = 870MHz to 1000MHz
	-17			dB	f = 1000MHz to 1200MHz
Output Return Loss	-20			dB	f = 45MHz to 320MHz
	-19			dB	f = 320MHz to 640MHz
	-18			dB	f = 640MHz to 870MHz
	-17			dB	f = 870MHz to 1000MHz
	-16			dB	f = 1000MHz to 1200MHz
Noise Figure		5.5	6.5	dB	f = 50MHz to 1200MHz
Total Current Consumption (DC)		230.0	240.0	mA	
Distortion Data 40MHz to 550MHz					$V_B = 24V, T_{MB} = 30^\circ C, Z_S = Z_L = 75\Omega, 79 \text{ ch. flat}, V_o = 44\text{dBmV at } 550\text{MHz, plus } 75 \text{ digital channels } (-6\text{dB offset})^{[2]}$
CTB		-64	-60	dBc	
XMOD		-60	-56	dBc	
CSO		-70	-65	dBc	
CIN	62	66		dB	

- The slope is defined as the difference between the gain at the start frequency and the gain at the stop frequency.
- 79 analog channels, NTSC frequency raster: 55.25 MHz to 547.25 MHz, +44 dBmV flat output level, plus 75 digital channels, -6 dB offset relative to the equivalent analog carrier. Composite Second Order (CSO) - The CSO parameter (both sum and difference products) is defined by the NCTA. Composite Triple Beat (CTB) - The CTB parameter is defined by the NCTA. Cross Modulation (XMOD) - Cross modulation (XMOD) is measured at baseband (selective voltmeter method), referenced to 100% modulation of the carrier being tested. Carrier to Intermodulation Noise (CIN) - The CIN parameter is defined by ANSI/SCTE 17 (Test procedure for carrier to noise).

Package Drawing

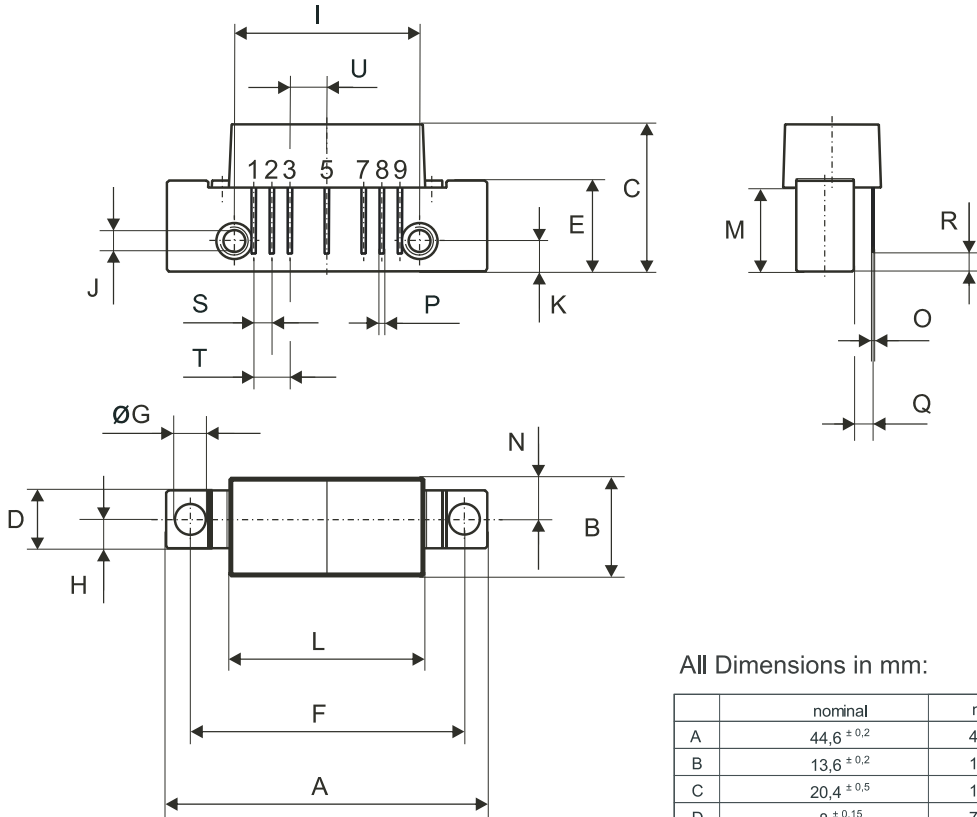

All Dimensions in mm:

	nominal	min	max
A	44,6 ± 0,2	44,4	44,8
B	13,6 ± 0,2	13,4	13,8
C	20,4 ± 0,5	19,9	20,9
D	8 ± 0,15	7,85	8,15
E	12,6 ± 0,15	12,45	12,75
F	38,1 ± 0,2	37,9	38,3
G	4 +0,2 / -0,05	3,95	4,2
H	4 ± 0,2	3,8	4,2
I	25,4 ± 0,2	25,2	25,6
J	UNC 6-32	-	-
K	4,2 ± 0,2	4,0	4,4
L	27,2 ± 0,2	27,0	27,4
M	11,6 ± 0,5	11,1	12,1
N	5,8 ± 0,4	5,4	6,2
O	0,25 ± 0,02	0,23	0,27
P	0,45 ± 0,03	0,42	0,48
Q	2,54 ± 0,3	2,24	2,84
R	2,54 ± 0,5	2,04	3,04
S	2,54 ± 0,25	2,29	2,79
T	5,08 ± 0,25	4,83	5,33
U	5,08 ± 0,25	4,83	5,33

Pinning:

	1	2	3	4	5	6	7	8	9
INPUT									
GND									
GND									
+VB									
GND									
GND									
OUTPUT									

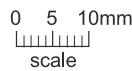

Notes:

